

DEUTSCH	Einbau- und Bedienungsanleitung
ENGLISH	Instructions for attachment and use
FRANÇAIS	Directives d'installation et mode d'emploi
ESPAÑOL	Instrucciones de montaje y de uso
ITALIANO	Istruzioni per l'uso e il montaggio
PORTUGUÊS	Manual de montagem e de utilização
NEDERLANDS	Inbouw- en bedieningshandleiding
NORSK	Bruksanvisning og monteringsveiledning
DANSK	Monterings- og betjeningsvejledning
SUOMI	Kiinnitys- ja käyttöohjeet

# CONCORD ULTIMAX.3



DEUTSCH	01
ENGLISH	19
FRANÇAIS	37
ESPAÑOL	55
ITALIANO	73
PORTUGUÊS	91
NEDERLANDS	109
NORSK	127
DANSK	145
SUOMI	163

**Kindergewicht** 0 - 18 kg  
child's weight 0 - 18 kg

**ca. Alter** 0 - 4 Jahre  
approx. age 0 - 4 years

**ECE Gruppen** 0+ und I  
ECE groups 0+ and I

**ISOFIX Gruppen** D und A  
ISOFIX groups D and A

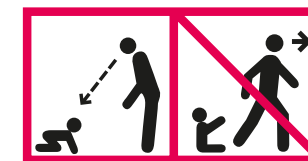

Norm ECE R44 04  
standard ECE R44 04  
norme ECE R44 04  
norma ECE R44 04  
szabvány ECE R44 04

Concord GmbH  
Industriestraße 25  
95346 Stadtsteinach  
Germany

Phone +49 (0)9225.9550-0  
Fax +49 (0)9225.9550-55  
info@concord.de

www.concord.de



UMI 05/0714 . IM 1710,00



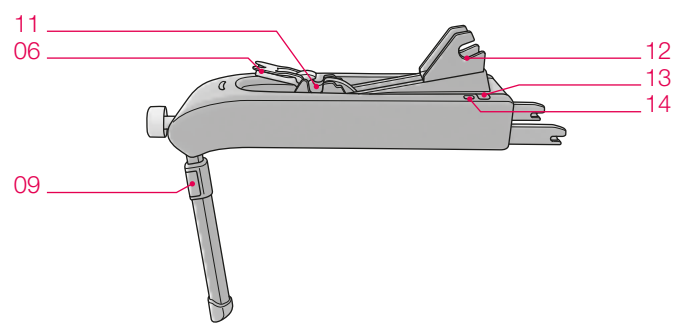
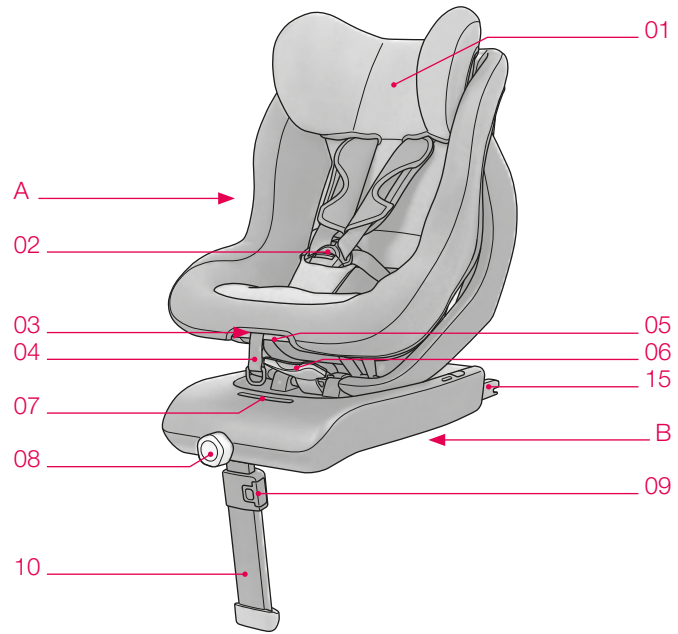

## **\_ ENGLISH**

IMPORTANT NOTES	20
OVERVIEW	22
USING THE ULTIMAX CHILD CAR SEAT	22
GENERAL GUIDELINES	23
FOR ISOFIX-SUITABLE VEHICLES	23
REMOVING THE SEAT	24
MOUNTING THE CONCORD ULTIMAX	25
MOUNTING THE SEAT OPPOSITE TO THE DRIVING DIRECTION (FROM BIRTH TO 13 KG)	26
MOUNTING THE SEAT IN THE DRIVING DIRECTION (FROM 9 TO 18 KG)	28
SECURING YOUR CHILD IN THE CONCORD ULTIMAX	30
REMOVING THE CONCORD ULTIMAX	32
USING THE TILT ADJUSTMENT	33
REMOVING / ATTACHING THE COVER	34
REMOVING THE PELVIC INSERT	35
CARE INSTRUCTIONS	35
WARRANTY CONDITIONS	36

## **\_ IMPORTANT NOTES**

### **CAUTION!**

Make sure you observe the relevant instructions in the user manual of your vehicle before transporting children. Take particular note of all information provided for the use of child seats in connection with airbags.

### **WARNING!**

- Children often carry small objects (e.g. toys) in jacket or trouser pockets, and may also wear clothes with rigid components (e.g. belt buckle).  
Make sure that these objects are not clamped between the child and the safety harness, as this might cause unnecessary injuries in case of an accident. The same hazards also apply for adults!
- Naturally young children are often lively. Make sure to explain the importance of safety when in a vehicle. Your child will then understand that the harness lock should not be opened and the harness should not be moved, giving you more peace of mind.
- Your child's safety can only be guaranteed if the safety system is installed and used in accordance with the instruction manual.
- All system harness straps must be worn taut and without any twists, and must be protected from damage.
- Protect any parts of the restraint system not covered with fabric against direct sunlight to prevent your child from suffering burns.
- The child restraint system must not be damaged or crushed by moving parts in the vehicle or by the vehicle doors.
- Do not attempt any modifications to the restraint system as they might endanger your child's safety.
- After an accident, the entire child restraint system must be replaced or sent to the manufacturer for testing, along with an accident report.
- Make sure to instruct your passenger on how to remove the child from its safety seat in case of an accident or danger.
- The lap belts of the harness system must be fitted as low down as possible so that the child's hips are held correctly.
- **The child seat must not be used on seats with activated front airbags. (Danger to life)!**

- Never leave your child unsupervised in the car seat - whether harnessed or not.
- Make sure you secure any luggage and loose items to reduce the risk of injury in case of an accident.
- The manual must always be carried with the child safety seat.
- The use of any accessories or replacement parts is prohibited, and non-compliance will result in the lapse of all warranty and liability claims. This only excludes original accessories from CONCORD.
- The child safety seat is to be used with original seat covers only.
- If the restraint system is used extensively it is normal for the seat covers and other parts to suffer varying degrees of wear, depending on the duration and intensity of use, and they will then have to be replaced. We can therefore not provide any blanket warranty beyond 6 months for wear parts.
- Please contact your specialist shop for baby and children's products and the relevant section of department stores, your car accessory specialist shop or a catalogue company for replacement parts. They will have a complete product portfolio for CONCORD child seat accessories to choose from.
- The child seat CONCORD ULTIMAX has been tested in crash simulations for impacts of up to 50 km/h against a solid obstacle. Test results are compliant with the international test standard ECE R 44 04, which is applicable for all tested child safety seat systems. When used as intended and in compliance with the installation and operating instructions, the child safety seat should prevent or minimise injuries to children up to a body weight of 18 kg in case of an accident, depending on the type and severity of accident.
- A child safety device does not replace responsible and careful behaviour in road traffic.

## \_ OVERVIEW

- 01 Headrest
- 02 Harness buckle
- 03 Central adjusting device
- 04 Central harness
- 05 Operating lever for the tilt adjustment mechanism
- 06 Unlocking device for the seat lock (with double switch)
- 07 Safety display seat lock
- 08 ISOFIX SYSTEM control dial
- 09 Support leg operating button
- 10 Support leg
- 11 Front seat lock
- 12 Rear seat lock
- 13 ISOFIX SYSTEM unlocking button (left and right)
- 14 ISOFIX SYSTEM safety displays (left and right)
- 15 ISOFIX adapter

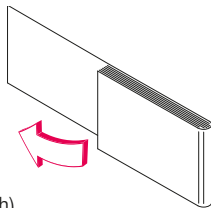

## \_ GENERAL INFORMATION

- This is an ISOFIX child restraint. It has been approved for general use in vehicles equipped with ISOFIX anchoring systems in compliance with ECE regulation 44, change series 04.
- It is suitable for use in vehicles with ISOFIX-approved seats (see documentation contained in the vehicle's operating manual) in accordance with the relevant child restraint and anchoring category.
- This child safety restraint is compliant with the ISOFIX weight category: up to 18 kg and ISOFIX size categories: D and A
- If you have any questions or doubts, please contact the manufacturer of the child safety unit or your retailer.

## \_ USING THE CONCORD ULTIMAX CHILD CAR SEAT

With the safety of your child in mind, you have decided to purchase our car seat CONCORD ULTIMAX. The product is manufactured under strict quality control conditions. Its optimum safety characteristics are only effective if the seat is used as intended.

As a result you should ensure strict adherence with the mounting and usage instructions.

The CONCORD ULTIMAX is suitable for children up to the age of approx. 4 or up to 18 kg. It is suitable for use in vehicles with ISOFIX-approved seats (see documentation contained in the vehicle's operating manual) in accordance with the relevant child restraint and anchoring category.

As a result of accident statistics, however, we recommend using the seat behind the front passenger seat.

The seat consists of 2 parts: the seat (A) and ISOFIX base (B).

## \_ FOR ISOFIX SUITABLE VEHICLES

The CONCORD ULTIMAX with ISOFIX system has been approved for 'semi universal' use, and is suitable for mounting on specific vehicle seats.

The appendix CAR FITTING LIST contains an overview of vehicles and vehicle seats that have been approved for using the CONCORD ULTIMAX with ISOFIX system in connection with a support leg. Should your vehicle not be listed, please ensure that the CONCORD ULTIMAX can be properly mounted in your car / on the desired seat before you purchase the child seat!

Read the user manual provided by the manufacturer of your vehicle and the mounting and security instructions contained in this user manual.

For latest updates, please visit: [www.concord.de](http://www.concord.de).

## \_ REMOVING THE SEAT

The seat (A) of the CONCORD ULTIMAX can be removed from the ISOFIX-Basis (B). **Always remove the child first before removing the seat!**

Move the tilt adjustment operating lever (05) at the front of the seat upwards and bring the seat into an upright position.

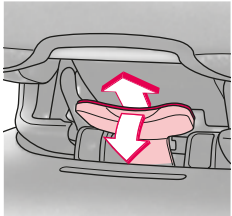
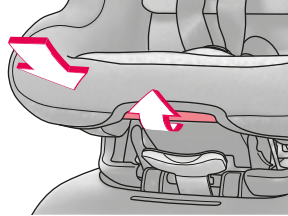

The unlocking mechanism of the seat lock (06) is at the front underneath the seat on the top of the ISOFIX base.

Pull the upper part of the lock (06) forwards and push the lock down.

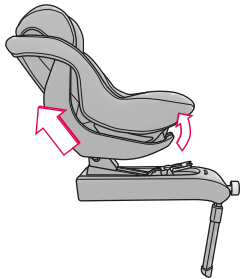

Lift the seat up off the base.

## \_ MOUNTING THE CONCORD ULTIMAX

To make mounting easier, we recommend removing the seat (A) of the CONCORD ULTIMAX from the base (B) (see „REMOVING THE SEAT“).

**Always mount and remove the CONCORD ULTIMAX without a child in it!**

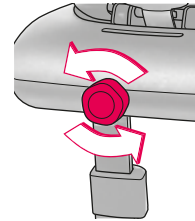

Turn the ISOFIX SYSTEM (08) control dial on the front of the CONCORD ULTIMAX ISOFIX base to the left until the ISOFIX adapter (15) on the reverse is fully extended.

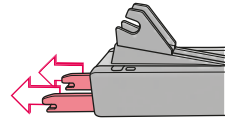

Place the base in the direction of driving on a vehicle seat equipped with ISOFIX receptacles.

Push the child seat backwards onto the ISOFIX receptacles until the locking mechanisms of both ISOFIX adapters (15) audibly lock into place and the safety displays (14) on both sides of the base are green!

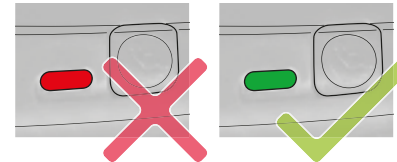
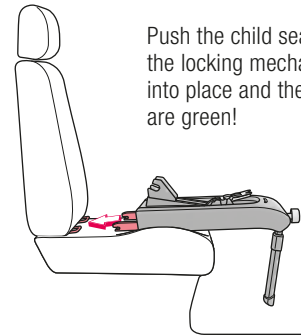

Now reinsert the seat, depending on the age of the child either in the driving direction or opposite to it (see „MOUNTING THE SEAT OPPOSITE TO THE DRIVING DIRECTION (FROM BIRTH TO 13 KG)“ or „MOUNTING THE SEAT IN THE DRIVING DIRECTION (FROM 9 - 18 KG)“).

## — MOUNTING THE SEAT OPPOSITE TO THE DRIVING DIRECTION (FROM BIRTH TO 13 KG)

### CAUTION!

Do not use on seats with airbags. Danger to life!  
Always mount the seat without a child in it!

Guide the seat (A) as shown, opposite to the driving direction over the base (B). First mount the frame of the seat into the seat lock (12) of the ISOFIX base.

Then fold the seat forward until the front seat lock (11) audibly locks into the ISOFIX base and the safety display (07) on the top is green.

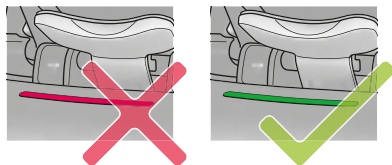
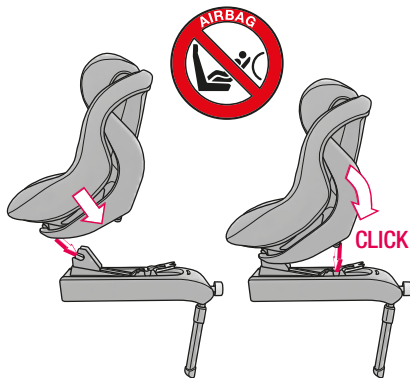

### CAUTION!

- Make sure that the seat is correctly anchored to both anchoring points and the safety display (07) is green!
- If the child's bodyweight exceeds 8 kg, the pre-installed pelvic insert should be removed (see „REMOVING THE PELVIC INSERT“).

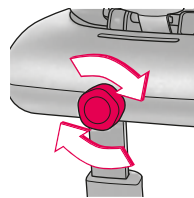

Turn the ISOFIX SYSTEM (08) control dial to the right until the CONCORD ULTIMAX lies as close/flush as possible to the back rest of the car seat.

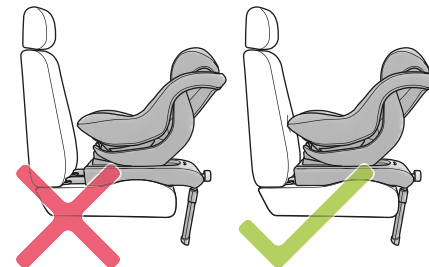

Push the release button (09) outward and position the support leg (10) so that it rests securely on the floor and the safety display shows GREEN.

Release the control button (09) to lock the support leg in place.

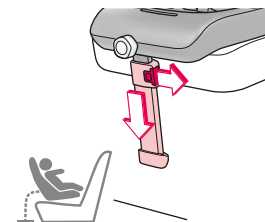

### CAUTION!

- The seat must be secured with the ISOFIX SYSTEM even if no child is travelling!
- Both ISOFIX adapters (15) must be locked securely in place and the safety displays (14) on both adapters must show green.
- The support leg (10) must rest securely on the floor and be locked into place.

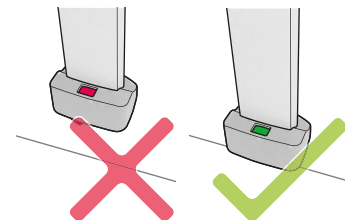

## \_ MOUNTING THE SEAT IN THE DRIVING DIRECTION (FROM 9 - 18 KG)

### CAUTION!

Mounting in the driving direction is only permitted for babies which weigh more than 9 kg and without the pelvic insert (see „REMOVING THE PELVIC INSERT“).

**Always mount the seat without a child in it!**

Guide the seat (A) as show, in the driving direction over the base (B).

First mount the frame of the seat into the rear seat lock (12) of the ISOFIX base.

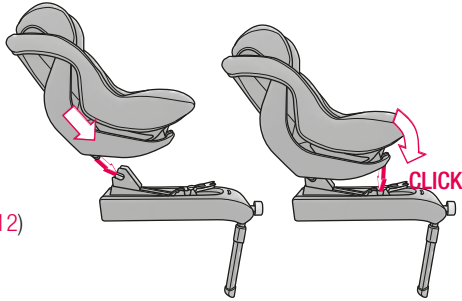

Then fold the seat forward until the front seat lock (11) audibly locks into the ISOFIX base and the safety display (07) on the top is green.

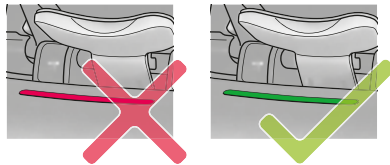
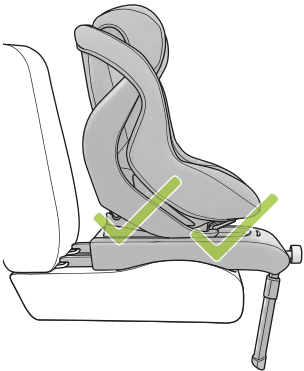

### CAUTION!

- Make sure that the seat is correctly anchored to both anchoring points and the safety display (07) is green!

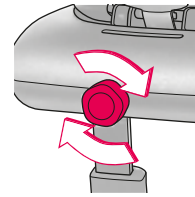

Turn the ISOFIX SYSTEM (08) control dial to the right until the CONCORD ULTIMAX lies as close/flush as possible to the back rest of the car seat.

In vehicles with series-standard headrests, a readjustment of the headrest or its removal will allow a better mounting position of the car seat.

Please remember to readjust or replace the headrest in the correct position if an adult is to sit in that place instead.

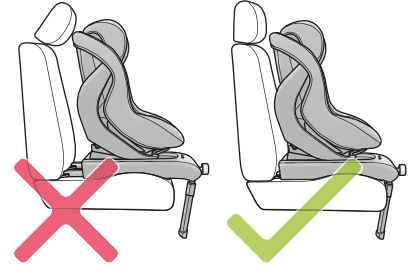

Push the release button (09) outward and position the support leg (10) so that it rests securely on the floor and the safety display shows GREEN.

Release the control button (09) to lock the support leg in place.

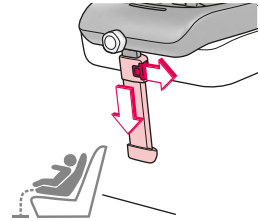

### CAUTION!

- The seat must be secured with the ISOFIX SYSTEM even if no child is travelling!
- Both ISOFIX adapters (15) must be locked securely in place and the safety displays (14) on both adapters must show green.
- The support leg (10) must rest securely on the floor and be locked into place.

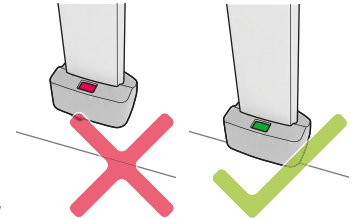



## \_ SECURING YOUR CHILD IN THE CONCORD ULTIMAX

### CAUTION

Check that the CONCORD ULTIMAX is mounted properly and that all belts have proper tension, and also that all locking mechanisms are secure before each use.

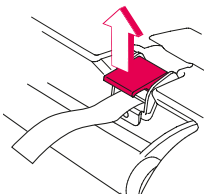

At the front of the seat under the cover there is the central adjusting device (03), which clamps the central harness (04) tight. Loosen the central adjusting device (03) by pushing the cap of the central adjusting device up and pull the harness forward (do not pull on the harness cushioning!).

Pull the head rest control, on the top edge, upwards and move the head rest to the highest position (01).



Open the harness lock (02) and move the harnesses to the sides and forward.

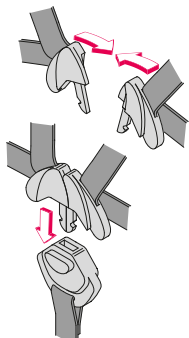

Place your child as far back into the seat as possible. Bring the shoulder/lap harnesses and the central harness together in front of the child and close the harness lock.

**Check that the harness lock (02) has latched shut correctly. Ensure that none of the harness straps are twisted.**

The CONCORD ULTIMAX must be adjusted to the size of the child.

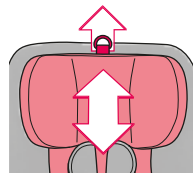

Pull the head rest control, on the top edge, upwards and move the head rest (01) to the suitable position for your child.

The shoulder harness guide should be situated slightly above the child's shoulder. The shoulder harnesses should lie in the middle between the child's neck and the outer edge of the shoulder.

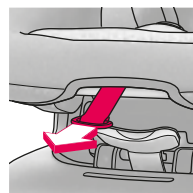
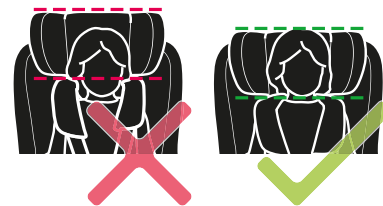

Tighten the harness by pulling the central harness (04) until it lies snug against the child's body.

### CAUTION!

- The harnesses must not be twisted.
- The harness lock (02) must be closed properly and the harnesses must lie snug against the child's body.
- The headrest/harness guide must be adjusted to the size of the child and latched securely in place.

## \_ REMOVING THE CONCORD ULTIMAX

To make the removal of the CONCORD ULTIMAX easier we recommend you first remove the seat (A) (see „REMOVING THE SEAT“).

**Always mount and remove the CONCORD ULTIMAX without a child in it!**

Push the release button (09) outward and move the support leg (10) into its top-most position.

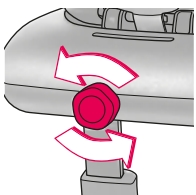

Turn the ISOFIX SYSTEM (08) control dial on the front of the CONCORD ULTIMAX ISOFIX base to the left and move the base forward.

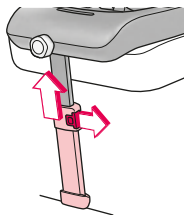

Push the ISOFIX SYSTEM unlocking buttons (13), on the left and right of the base, so that the ISOFIX adapters (15) are released from the receptacles and the base springs forward.

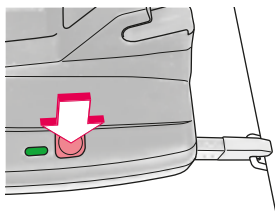

Lift the CONCORD ULTIMAX out of the car seat.

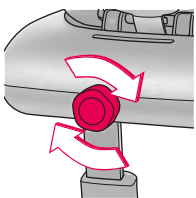

Turn the ISOFIX SYSTEM (08) control dial to the right until the ISOFIX adapter (15) is fully extended.

## \_ USING THE TILT ADJUSTMENT

Move the tilt adjustment operating lever (05) at the front of the seat upwards and bring the seat into the desired position.

By releasing the lever (05) the seat is locked.

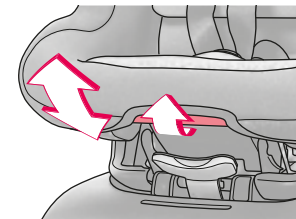
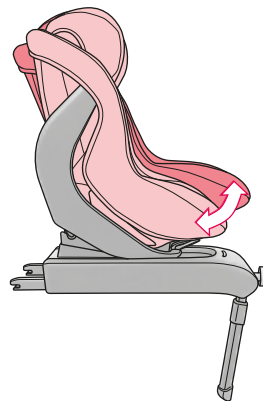

## \_ REMOVING / ATTACHING THE COVER

To remove the cover the seat (A) has to be removed from the base (B) (see „REMOVING THE SEAT“).

Loosen the rubber bands and push buttons of the cover, which are located in the places marked red on the reverse side of the cover.

Open the harness lock (02).

First remove the cover from the head support (01).

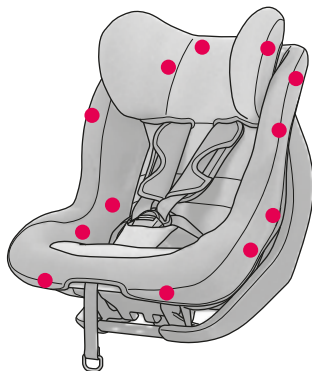

Thread the harness lock (02) through the harness lock cushioning and out underneath the cover.

Open the Velcro fastener on the harness guides and remove the cover from the seat.

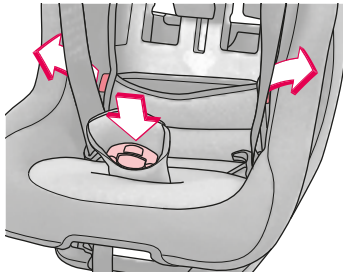

The covers are attached in reverse order.

**Check that all the locks are closed and all anchorings are correctly fastened.**

## \_ REMOVING THE PELVIC INSERT

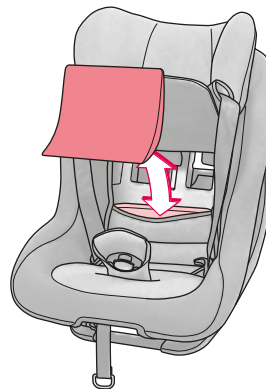

If the child's bodyweight exceeds 8 kg, the pre-mounted pelvic insert should be removed.

This can be found in a pocket under the seat, on the reverse of the seat cover.

## \_ CARE INSTRUCTIONS

Light dirt can be easily removed with a damp cloth. The cover can also be removed and washed at 30°C. Remove the back cushion from the cover of the head support before you wash it.

The cover material colour may run slightly when wet, in particular during washing.



Do not use solvents on the cover!

## **WARRANTY CONDITIONS**

The warranty period begins at the time of purchase.

The warranty period granted is compliant with the legal warranty period in the country of purchase. In terms of content, the warranty covers rework, replacement delivery, or a rebate as the manufacturer sees fit.

The warranty applies only for the original user. In case of a fault, warranty rights will be applicable only if the dealer, where the item was purchased, is notified immediately after initial detection. Should the dealer be unable to remedy the issue, then the product will be returned to the manufacturer with a detailed description of the fault, and with the official purchase document including the date of purchase.

The manufacturer shall not accept liability for faulty products not delivered by him.

Warranty claims are void if:

- the product was modified.
- the product is not returned complete and accompanied by the original purchase document to the dealer within 14 days of the detection of the fault.
- the fault occurred due to inappropriate handling or maintenance, or due to other actions that are the fault of the user, specifically where the user instructions were not complied with.
- repairs on the product were carried out by third parties.
- the defect was caused by an accident.
- the serial number has been damaged or removed.

Modifications to or deterioration of the product caused by the contractually agreed use of the item (normal wear and tear) will not be accepted as a warranty claim.

Any services rendered by the manufacturer in case of a warranty claim shall not extend the warranty period.

# CONCORD ULTIMAX.3

D // Um die Funktionsfähigkeit und Sicherheit Ihres Kinderautositzes auch nach dem Austausch von Ersatz- und Zubehörteilen zu gewährleisten, bitten wir Sie bei Bestellungen Ihrem Fachhändler nachstehende Angaben mitzuteilen:

EN // To ensure the functionality and safety of your child's car seat after replacing spare and accessory parts, please provide your dealer with the following details when placing your order:

F // Dans le but d'assurer le bon fonctionnement et la sécurité de votre siège auto enfant, également en cas de remplacement de pièces de rechange et accessoires, nous vous prions de bien vouloir, en cas de commande, donner les renseignements suivants à votre revendeur :

E // Para seguir garantizando el correcto funcionamiento y la seguridad de su asiento para niños después del cambio de piezas o accesorios, le rogamos que indique los siguientes datos al realizar pedidos a su comercio especializado.

I // Quando trasmette un ordine al Suo rivenditore di fiducia, La preghiamo di comunicargli i dati seguenti per garantire la funzionalità e la sicurezza del Suo seggiolino per bambini anche dopo la sostituzione di parti di ricambio e di accessori.

ECE-Nr.  
ECE No.  
N° ECE  
Número ECE  
N° ECE

①

Serien-Nr.  
Serial No.  
N° de série  
Número de serie  
N° di serie

②

Ersatzteil  
Spare part  
Type de siège  
Pieza de repuesto  
Parte di ricambio

Fachhändler  
Dealer  
Revendeur  
Comercio especializado  
Rivenditore specializzato

Meine Anschrift  
My address  
Mon adresse  
Mi dirección  
Il mio indirizzo

**CONCORD**

Industriestraße 25  
95346 Stadtsteinach  
Made in Germany

semiuniversal  
0 - 18 kg

E 9

① 04.....

② 0000000000

# CONCORD ULTIMAX.3

P // Para garantir a funcionalidade e a segurança da cadeira de criança para automóvel depois da substituição de peças sobressalentes e de acessórios, agradecemos o fornecimento dos dados seguintes à loja especializada a quando de encomendas:

NL // Om de functionaliteit en de veiligheid van het door u gekochte autokinderzitje ook na vervanging van onderdelen en accessoires te waarborgen, is het belangrijk dat u bij de bestelling in uw speciaalzaak onderstaande gegevens vermeldt:

N // Bilbarnesetet som du kjøpte, skal fungere riktig og gi optimal sikring også etter at reservedeler eller tilbehør er byttet ut. Ved eventuelle bestillinger bervi deg derfor om å gi forhandleren følgende opplysninger:

DK // For at garantere at autostolen stadig er funktionsdygtig og sikker, også efter at der er blevet monteret reservedele eller tilbehør, bedes De oplyse følgende til Deres forhandler ved bestillingen:

FIN // Lasten turvaistuiemen toiminnan ja turvallisen käytön varmistamiseksi myös varaosien tai lisävarusteiden asennuksen jälkeen anna jälleenmyyjälle seuraavat tiedot, kun tilaat osia:

Nº. ECE  
ECE-nr.  
ECE-nr  
ECE-nr.  
ECE-nro ①

Nº de série  
Serie-nr.  
Serienr.  
Serienr.  
Sarjanro ②

Peça  
Type kinderzitje  
Reservedel  
Reservedel  
Varaosas

Loja especializada  
Speciaalzaak  
Forhandler  
Forhandler  
Jälleenmyyjä

Meu endereço  
Mijn adres  
Min adresse  
Min adresse  
Oma osoite

